

TEBAS Full Inverter model CP 35-70-130-170-260-320-370 ES

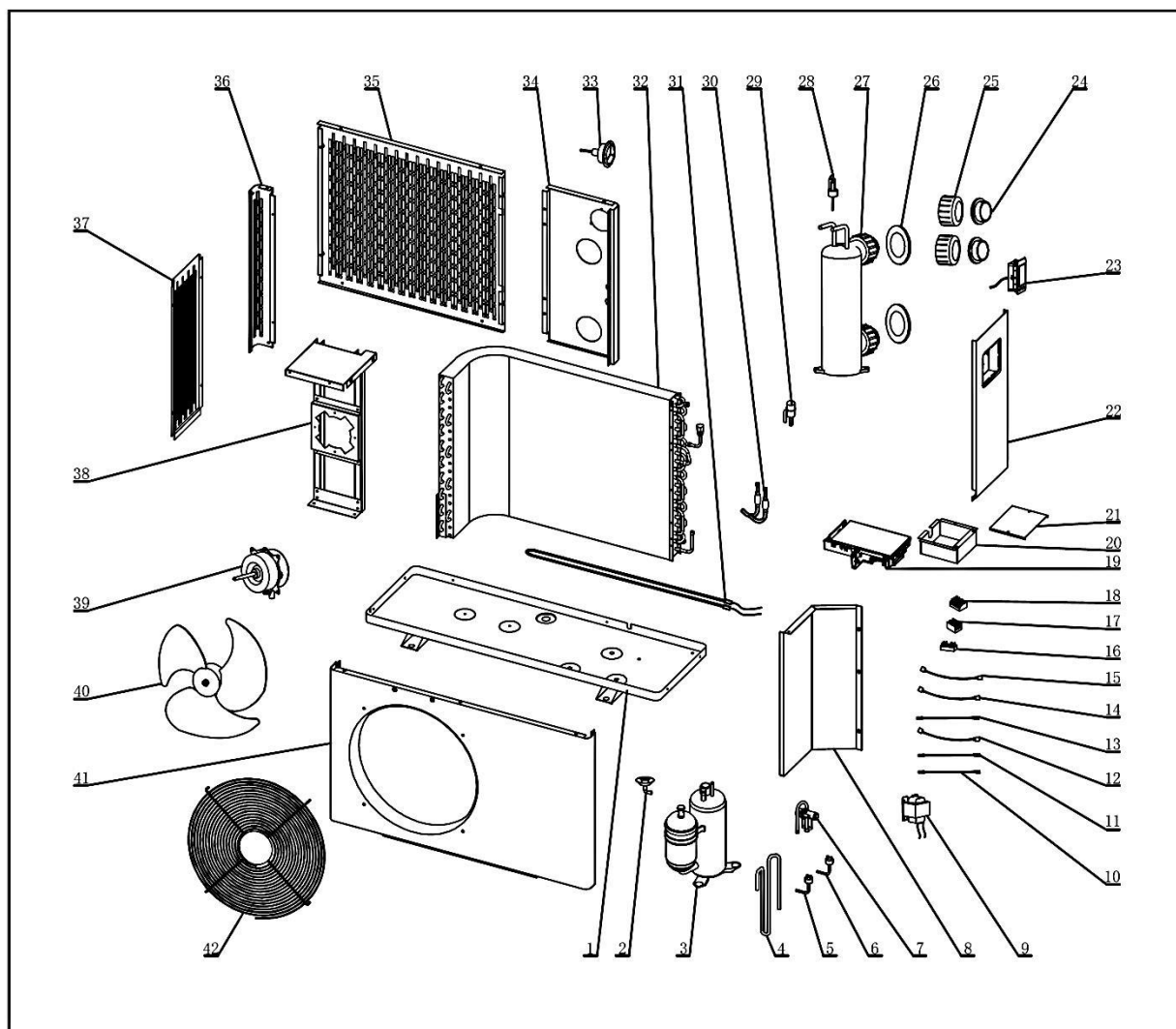

1	Frame	16	Public terminal	31	Heating strip
2	Drain nozzle	17	Water pump terminal	32	Condenser
3	Compressor	18	Terminal	33	Pressure manometer
4	Copper pipe	19	Circuit board	34	Rear panel
5	Low pressure interruptor	20	Electrical box	35	Rear net panel
6	High pressure interruptor	21	Electrical box cover	36	Left pillars
7	Four way valve	22	Right size board	37	Left size board
8	Verge board	23	Wire controller	38	Motor bracket
9	Reactance	24	Joint water connection kit	39	Fan motor
10	Water inlet sensor	25	Water connection kit	40	Fan
11	Water outlet sensor	26	Rubber water fender	41	Front panel
12	Compressor sensor	27	Titanium heat exchanger	42	Fan protection net
13	Copper sensor	28	Water flow switch	43	
14	Ambient sensor	29	E E Valve	44	
15	Return gas sensor	30	Filter	45	